

Skip
**MODEL
DESIGNS**
International
521. Unitmate 10-300

Thank you for purchasing the Skip Model Designs 52% Ultimate Biplane. If you have any issues, questions, concerns or problems during assembly, please contact us :

Hello @skipmodeldesigns.co.uk

SAFETY in Assembly

During assembly of this aircraft, you will be asked to use sharp knives and hobby adhesives. Please follow all safety procedures recommended by the manufacturers of the products you use, and always follow these important guidelines:

- ALWAYS protect your eyes when working with adhesives, knives, or tools, especially power tools. Safety glasses are the best way to protect your eyes.
- ALWAYS protect your body, especially your hands and fingers when using adhesives, knives, or tools, especially power tools. Do not cut toward exposed skin with hobby knives. Do not place hobby knives on tables or benches where they can roll off or be knocked off.
- ALWAYS have a first-aid kit handy when working with adhesives, knives, or tools, especially power tools. ALWAYS keep hobby equipment and supplies out of the reach of children.
- SAFETY in Flying! This is NOT a toy! It is a very high-performance RC airplane capable of high speeds and extreme manoeuvres. It should only be operated by a competent pilot in a safe area with proper supervision.
- ONLY fly your aircraft in a safe, open area, away from spectators and vehicles and where it is legal to fly. NEVER fly over an unsafe area, such as a road or street.
- NEVER fly near overhead power or utility lines. If your airplane ever becomes stuck in a line or a tree DO NOT attempt to retrieve it yourself. Contact the authorities for assistance in retrieving your aircraft. Power lines are DANGEROUS and falls from ladders and trees CAN KILL!
- Never fly too close to yourself or spectators.
- Spinning propellers are DANGEROUS! Never run your motor inside a house or building with the propeller attached. Remove the prop for safety. ••• Always fly within your control.
- Always follow manufacturers instructions for your radio system.
- Always perform a pre-flight check of your aircraft to be certain of the aircraft's airworthiness.
- Always obtain proper insurance before flying. Always fly model aircraft in accordance with the Academy of Model Aeronautics (AMA) Safety Code and BMFA/LMA. Please visit These websites easily found in major search engines.

Limits of Responsibility

Skip Model Designs provides high-quality aircraft and components to its customers and end users. These aircraft and components are assembled by the end user to produce a flying model. It is beyond skip model design's to monitor the end user's completed aircraft. Therefore, Skip Model Designs in no way accepts or assumes responsibility or liability for damages resulting from the end user assembled product. The end user assumes all responsibility and liability in use of Skip Model

Designs and components

Required Items

- Masking or painters tape
- Various Balsa woods detailed in the Packing Sheet
- Various Carbon Fibre Rod
- Various Sized, Nuts, Bolts and General Building Supplies
- Hobby knife with #11 blades.
- Fresh 30 minute & 15 Minute epoxy.
- Plenty of both Medium and Thin CA.. Activator can also be used.
- Electric drill with an assortment of small drill bits.
- Small flat head and Phillips head screw drivers.
- Standard and needle nose pliers.
- Hammer, Hacksaw and other basic Hobbies Tools
- Metric ball driver or allen key set.
- Sanding block and sandpaper. Hobby Plane
- 16 x High Torque 30kg Servo
- 6" Spinner
- 210cc + Sized Gasoline Engine

Make sure that the plane is secured properly when you start up the engine.

Have at least 2 helpers hold your plane from the tail end or from behind the wing tips before you start the engine. Make sure that all spectators are behind, or far in front, of the aircraft when running up the engine.

Make sure that you range check your R/C system thoroughly before the first flight. It is absolutely necessary to range check your complete R/C installation first WITHOUT the engine running. Leave the transmitter antenna retracted, and check the distance you can walk before 'fail-safe' occurs. Then start up the engine, run it at about half throttle and repeat this range check with the engine running.

Make sure that there is no range reduction before 'fail-safe' occurs. Only then make the 1st flight. If you feel that the range with engine running is less than with the engine off, please contact the radio supplier and the engine manufacturer and DON'T FLY at that time.

Check for vibrations through the whole throttle range. The engine should run smoothly with no unusual vibration. If you think that there are any excessive vibrations at any engine rpm's, DON'T FLY at this time and check your engine, spinner and propeller for proper balancing. Due to the model's construction (Been Light) it is very important to have everything running smoothly

Elevator and Stab Assembly

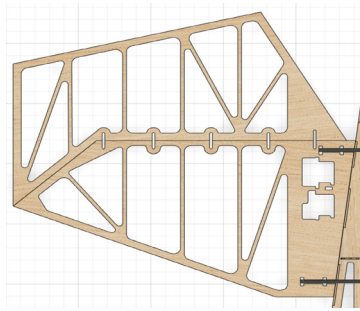

9.5MM Balsa
3MM POPLAR PLY CORE
9.5MM Balsa

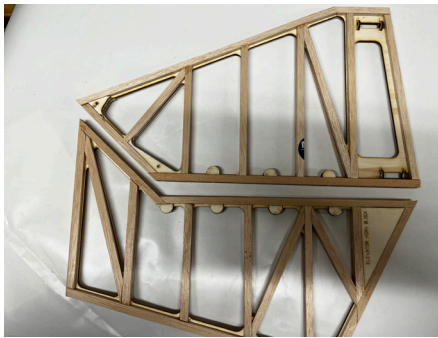

Please note: Servos fit in Stabs on production models



With Any model build, It is important to test fit components together before gluing (Where applicable). 5 Minutes test Fitting can save hours of Unpicking.

To build ANY COMPONENT of this model, Please make sure you have a large enough area to work safely, and that your work bench for the next few months is clean, tidy and most importantly FLAT

First Part of the build is the elevator and Stab(The most simple parts to build on the model)

Inside the kit you will find 4 Parts which are made from 3mm Poplar Ply (They look like the attached picture In Shape)

These are the cores of the elevators and stab.

To Begin the build, Put all the parts flat on a Board and find the 6.5mm x 9.5mm Balsa Strips and the 6.5 x 9.5mm Spruce strips

When building the elevator and stab. You have to do 1 side of the elevator and Stab at a time (DO NOT, Keep turning the parts over as this could warp the elevator and stab)

The spruce strips are for the REAR of the elevator Stabs & rudder fin..

***** PLEASE READ THIS PART BEFORE BUILDING TO MAKE A DECISION*****

We recommend you glue the spruce with 30 minute Epoxy.

1 Strip of 6.5mm x 9.5mm Spruce will do both sides of 1 Stab. Glue the 6.5mm x 9.5mm Spruce Strip upwards, so that the 6.5mm Side sits flat to the 3mm Core. After you have glued the spruce to the rear of the stab, It is the matter of cutting and Sticking the Balsa Strips to the Stab and elevator..... We used Super-glue for this. Again the 6.5mm Side of the Balsa sits flat on the core Please Glue all Balsa wood to the elevator and stab Like image shown

We have marked on the Plywood core where the reinforcement blocks are to be placed for the Steelwork and Horn Blocks and also the rear tube support. These are made a balsa sandwich. 6.5mm then a piece of 3mm Ply..

Once one side of the elevator and Stab is complete, flip the elevator and stab over and repeat the entire process again ensuring the elevators are kept flat.

When the Elevator Stabs are complete, Drill the Holes in the Steel work Reinforcement Areas with a 3mm Drill

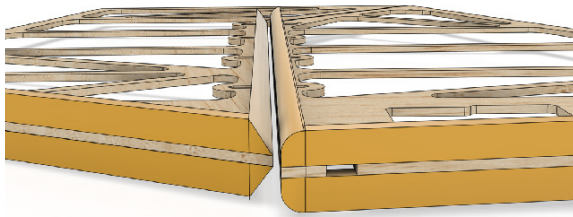

The Front of the Elevator is to have a 45% chamfer to each side. This will give you 45 Degrees Of Movement, Please Adjust to your Flying Style, But we do not recommend more than 50 Degrees or less than 30 Degrees. as this is a very sensitive surface.

The Hinges for the Elevators are Made by Robart. Simply drill through the pre market holes and test fit the hinges in place at this point. Do not glue in place. This will be done at the final fit of the model after covering

Drill through the Balsa wood mating surface on the elevator stabs and Insert the 8mm Carbon tubes in to the designated cut outs on the elevator stabs and holders.

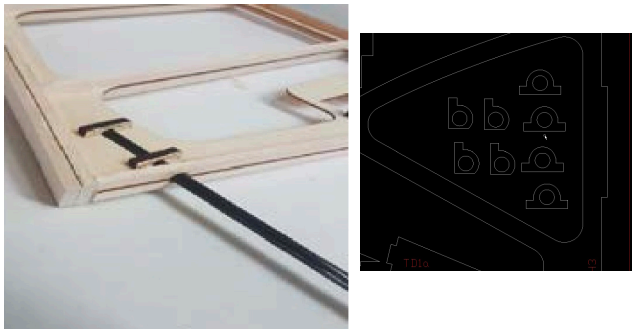

.. These are glued in place with epoxy..

Ensure a good glue joint between the elevator stabs and the Carbon, We recommend gluing both sides to ensure a strong bond

These act as the antirotation pins on elevators.

Trim off any excess by simply sanding this off.

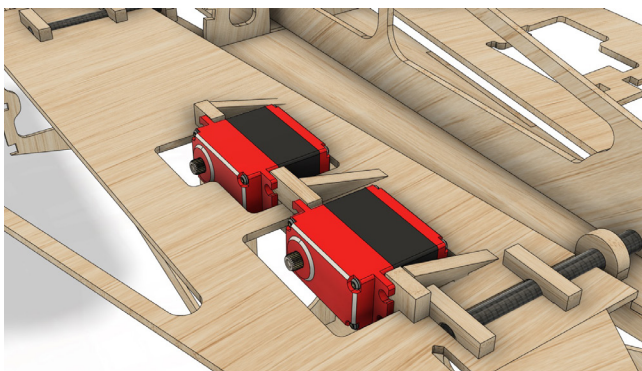

The Elevator Servo blocks are made from 6mm ply (S1,S2 & S3) there orientation is shown the the photos use Epoxy to glue in place. At this point we recommend test fitting the servos and drilling the Blocks as it will make it easier to assemble the model later.

A Small Hatch will need to be made which sits on the outside of the model to access the servo from the underside when covered

The Elevator Front edge is made up by gluing a strip of 6.5mm Balsa to the front and rounding.

There are 2 areas that a required rounding
Front Edge of elevator stabs and the Triangle face of the elevators, as shown in the image

At this point the elevators and stabs can have a pre-final sand as they are complete.

Next Up Rudder and Fin

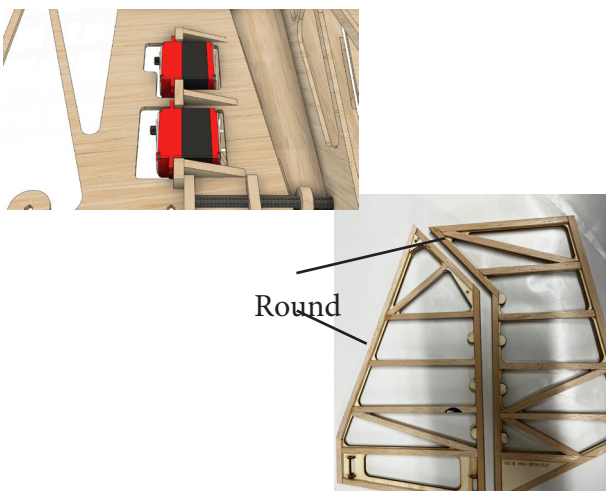

Rudder Assembly

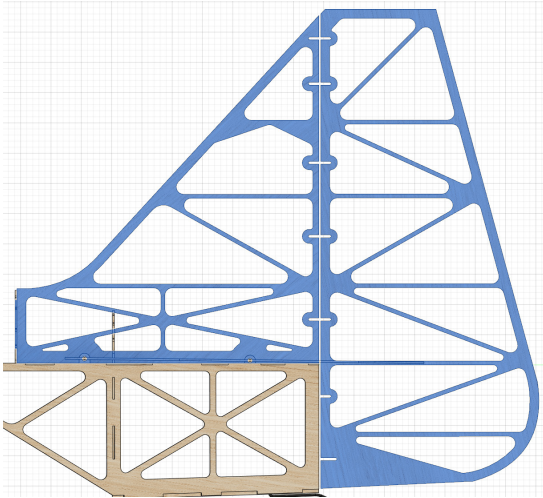

Construction is similar to elevator using the same 6.5mm x 9.5mm Spruce and 6.5mm x 9.5mm Balsa. finished thickness is 22mm

The Fin Rear is to have the Spruce Glued to it with epoxy. Do NOT CUT EXCESS OFF. You will need approx 350mm to extend past Fin at bottom which will fit in to fuselage later (Please see photo for reference of what me mean!)

Please note : At base of Fin there are 2 holes of 8 mm diameter, these correspond to the holes in horizontal stab set to 1.5 degrees of incidence. It is important you drill

these holes as you cover them with balsa strip otherwise you will loose location of rear stab



The Blocks for the Rudder and steel work are pre-made from 6mm Balsa ply and 3mm Ply

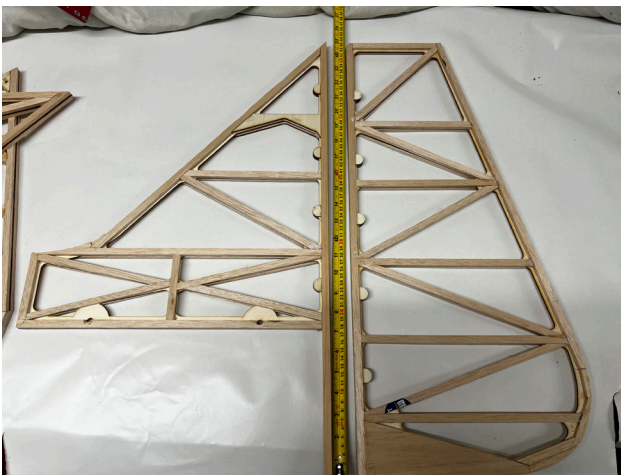



Skip
MODEL
DESIGNS
International

Fuselage Assembly

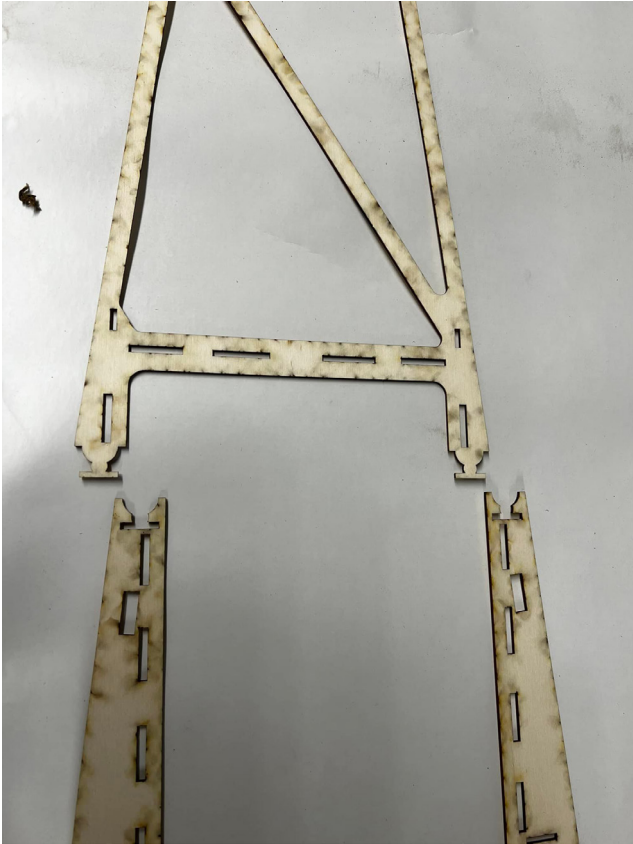

In The fuselage, You will find alot of parts Labeled with acronym's. Once you get the hang on how they are labeled, and meanings like SD (Servo Doubler), MUCP (Main UnderCarriage Plate) it will be easy.

So you have built the elevators and rudder? Congrats.. If not... Go back and start the build with easy parts :D

The fuselage is relatively Simple..... Other than the front end of the fuselage... PLEASE be very patient when building the front end of the model!. All Parts DO go together.. But are an extremely good fit.. You will require a Rubber Hammer

We could have made this part a little sloppy going together,

however, all the forces of the undercarriage, Wing wires and engine all go through these parts!.

We accept everyone will curse us when putting this together!..... But its for the good of the model!

The first 5 ribs are a while away...So lets start off with some easy bits first.

First of all. You need to join a few parts of the fuselage together.

Fuselage Top (3mm Ply).

The fuselage top can be glued together with Superglue or epoxy, the choice is yours.

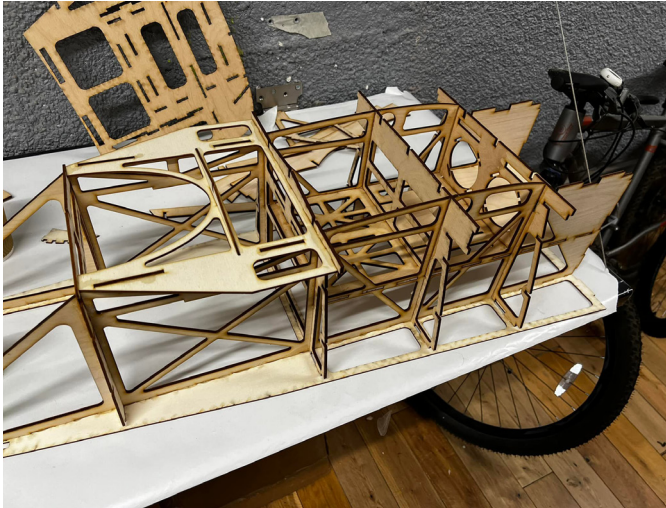

Ok.... So we may have lied about not doing the first 4 ribs first, We thought we would put your mind at ease..... Then Jump Straight in to it!..... Element of surprise :)

With the model been built upside down, this ensures the entire plane is built true and straight.

We will do this as numbers to make it a little easier to get the grasp of

1) Add the 2 fuselage Sides to the Fuselage top. These need to be glued using 30 minutes epoxy Or longer if you are unsure of your building speed as all the following steps need to be done at once! Use epoxy throughout

2) Add The Fuel Tank tray

3) Add F4

4) Slide in F3, test fit this before gluing as it may be a little tight, Simply file or sand the mating faces. A rubber happer is useful on the.

5) Add F2 Using the same principle as above.

6) Add F5, Using the same as above

7) Add FB between F4 AND F5

8) Add the F4B to the Wing Flair.

Before continuing, this will all need to dry.

** As a note, Make sure to wipe all excess glue off.

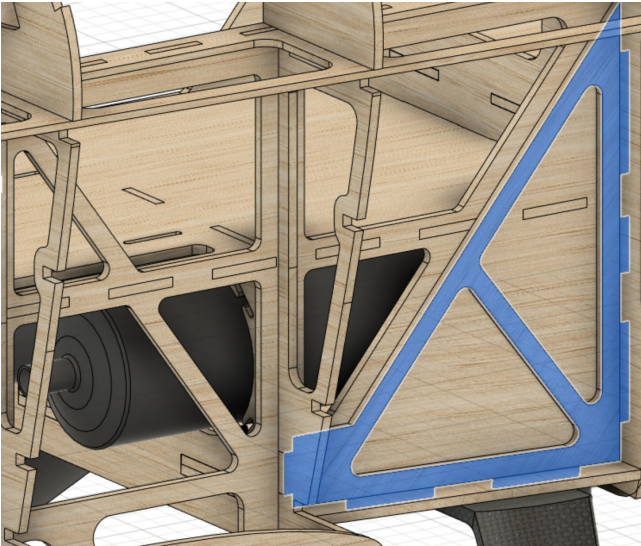

Once the fuselage is dried, you now need to add the undercarriage Side doubler, Undercarriage Doubler and Main UC Plate. Use 30 Minute Epoxy,

Before Gluing the Main UC Plate in place. Make sure the Undercarriage doubler is covered with epoxy. Use weights to hold in place while it is drying.

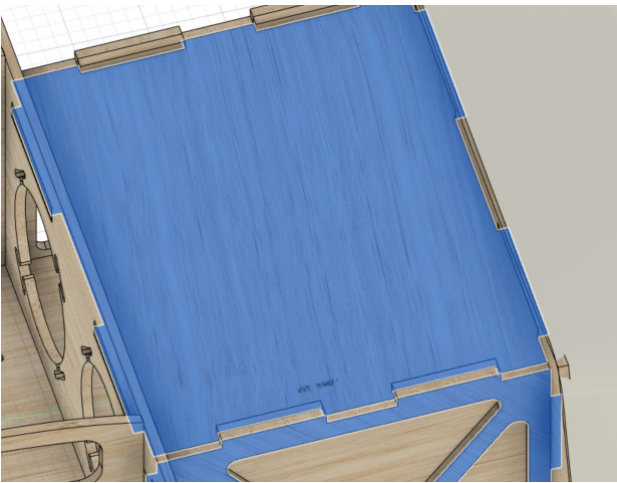

Image Shows Undercarriage Doubler which fits on the inside of the model

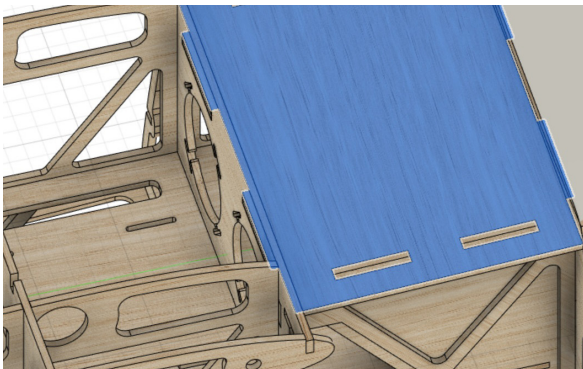

Image Shows Undercarriage Plate.



Next is add F1. This is where the Rubber hammer comes in handy
With the front of the fuselage over the bench, Dry fit F1 to the Fuselage, you may need to chamfer all mating faces to get to go in place.

Once you are happy with a firm fit. Remove F1 And Add glue to all mounting Faces. Allow to fully dry before moving. We recommend 30 mins epoxy



Leave F1 Hanging over the edge of the deck and now add all other fuselage ribs
 * F6 - F8 - Ensure these are square to fuselage, use super glue to stick in place.

The Following needs to be glued with epoxy

- * Rear UC Sides
- * Rear UC Plate

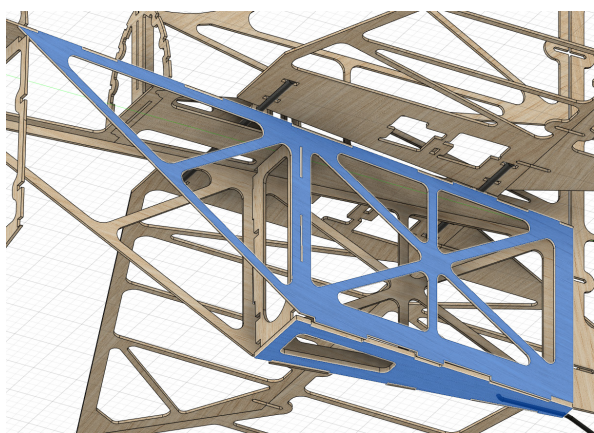

With all the Ribs in place, it is now time to add the 2200mm Obechi/ Spruce Strip to the Fuselage.

Only 3 of the 5 Pieces run the entire length of the fuselage.

Use epoxy throughout to putting the strips in place.

1 & 3 run Full Length of the Fuselage
 2 Run from rear of fuselage and terminate at F4 (Area shown in photo)

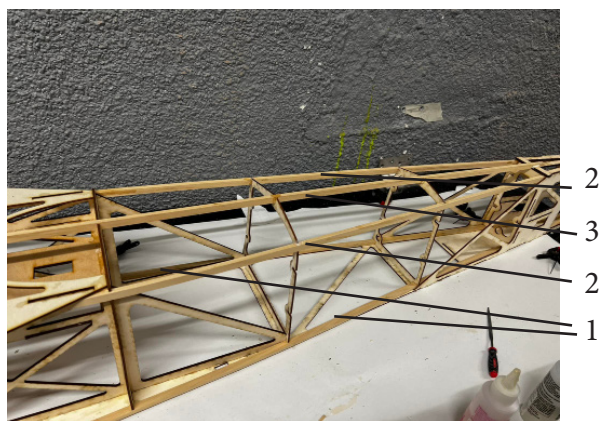

Please ensure no3 Runs under the Rear UC Plate and is glued with epoxy. Make sure to get a Hard fit against Rear UC Sides and Rear UC Plate.

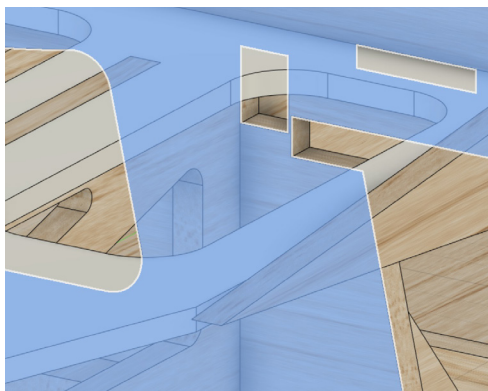

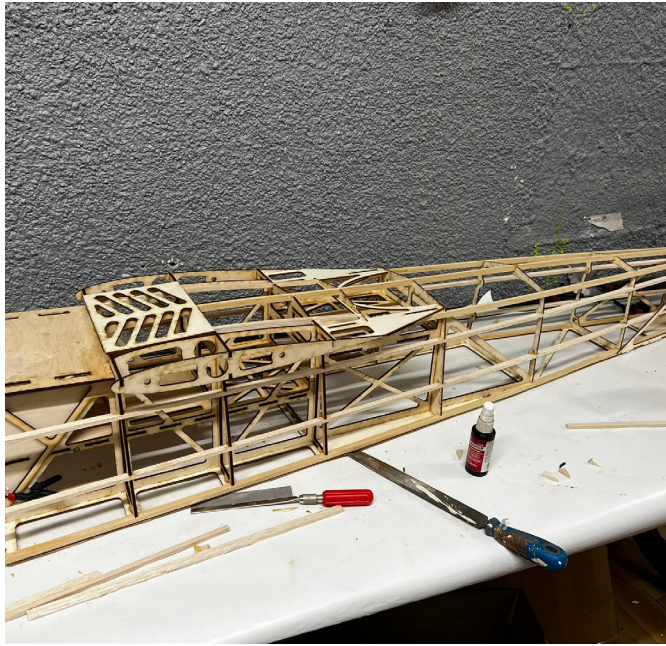

Fit The 6.5 mm x 9.5mm Balsa wood Stringers to the Fuselage. You will need to join these with a scarf joint. Use Superglue to a good strong bond. Ensure these run in to the Rear UC Sides. We recommend adding a joining strip inside the rear UC area



"Dont Forget to add me hidden here :)"

These Balsa Stringers are only between F2 AND F4B. Where is stringer Meets F4B you will need to sand to make a good fit. Superglue in place



The Exhaust Hatch can now be added to the model by using scrap pieces of wood for screw points in each corner



Add FLWM to the Fuselage Sides.



The Phenolic tube can be added to the model. You will need to notch the Obechi Middle Strip to get the Phenolic in place. Glue in place with Epoxy.



After all of this is done and Glues, You can now flip the model over and take a look at your lovely Boat Hull..... Did we not say, were making an ultimate boat :)

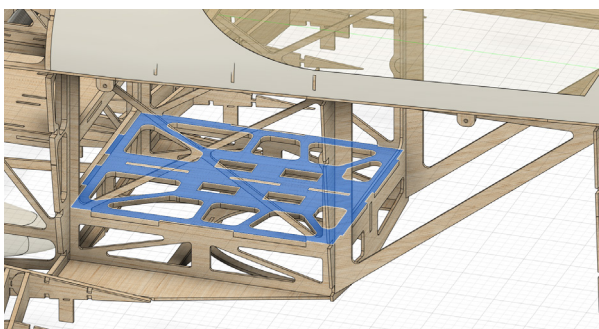

Now we can gain access from above, we can now add the servo tray. Use epoxy on all mounting surfaces.



FT2, F3T AND F4T Can be glued in place Using epoxy.
You can also at this point add TWM

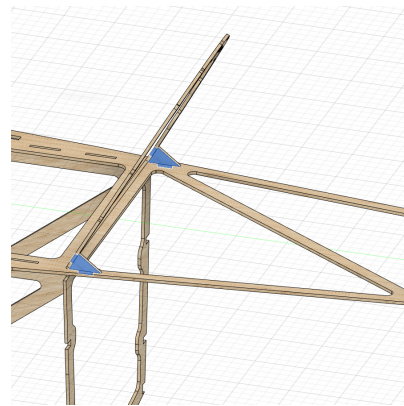

Rear Turtle Deck Ribs can also be added, use CA to get the angle of F6T Correct. These Can be glued with Superglue. Do Not Place F9T in Place Just yet

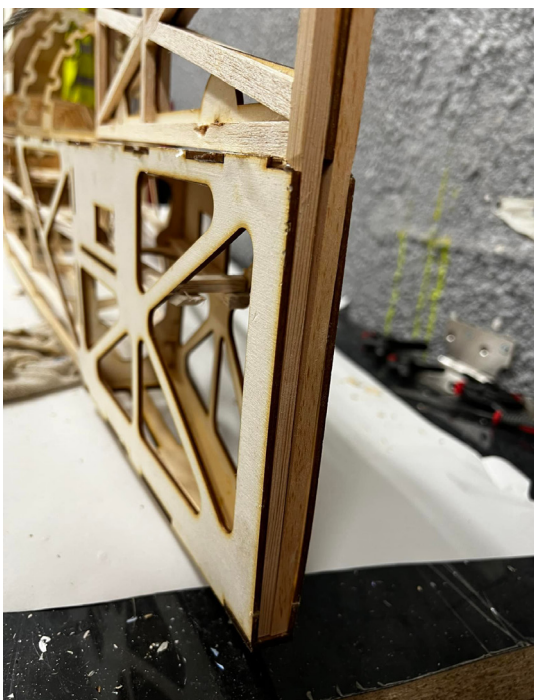

The Rudder Stab Can be added to the fuselage. This interlocks in to F8T.

The 2 pieces of Spruce from the Rudder fin will need to be cut to length and Shaved slightly to get to fit in the Rear Undercarriage Sides. Ensure the rudder stab is at 90 Degrees to the model.
Use Epoxy to glue in place, ensure a hard fit!



A small Strip of balsa wood can be glued between the spruce on the stabs. Superglue will be perfect for this.

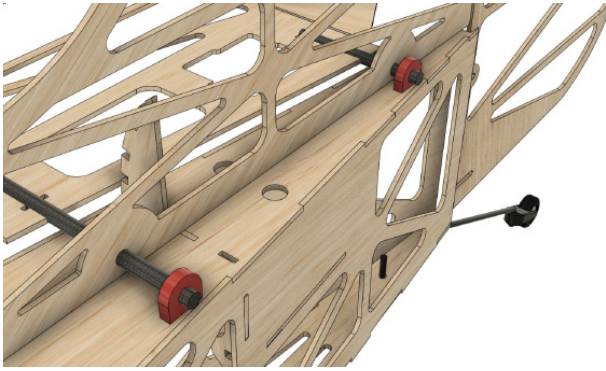

In the Kit, there is also 4 Parts Called STM. These parts are used to set the Elevator Angles

Put the 8mm Carbon through the Stab AND through STM Both Sides.

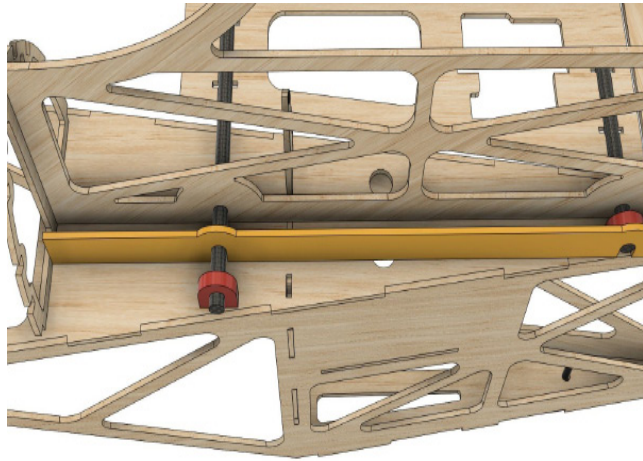

In the Kit you will also find 2 x Alignment tool for the Elevators. This is placed against F8

With all 4 STM and The 2 x Alignment tool in place. This should align the elevators perfectly

Tac Glue STM in place with super glue. The Tool can now be removed.

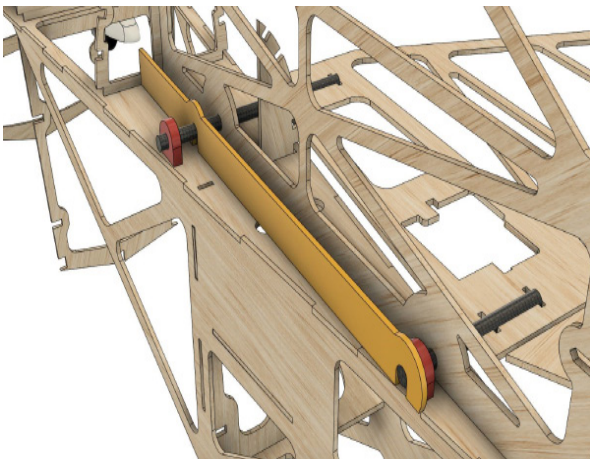

It is now worth sliding both elevators on the the model to ensure they fit correctly.

Trim the 8mm carbon flush with the Rear UC Sides.

Slide in the 6mm Carbon Tubes and slide the elevators in to place.

You will need to cut down the 6mm carbon to size so that that they fit the fuselgs and Tails correctly.

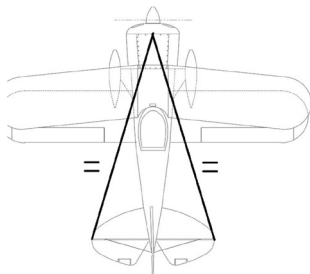

Take Measurements from 2 known places to ensure the elevators are the same.

Once satisfied that everything is correct. STM Can now be perminantly glued in place.

F9T can now also be glues in place.

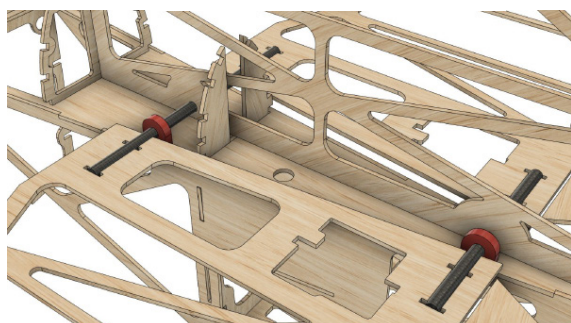

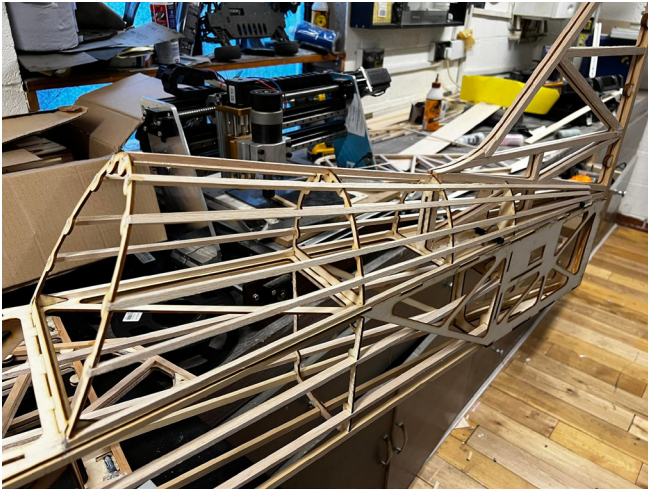

After the elevators are mounted correctly, The 5mm x 5mm Stringer can now be added to the rear turtle deck! Superglue is fine for this.

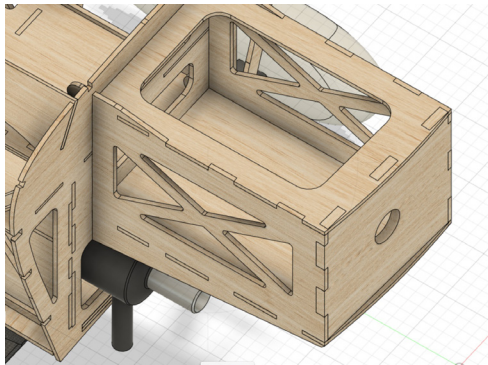

Assemble the engine box using epoxy., Make sure the engine box has right hand thrust (Like the shown photo)

When the box is assembled, Epoxy all mating faces and fit to F1. There are also T Key and B Key to add (See image) These are to be hammered up for top location tab, and down for bottom tab from behind F1. This secures the Engine box to F1. Use Epoxy to glue in place.

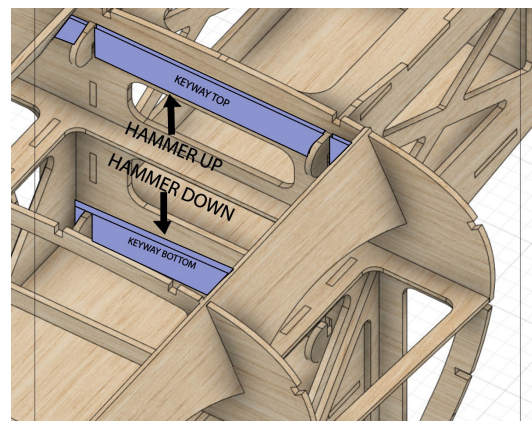
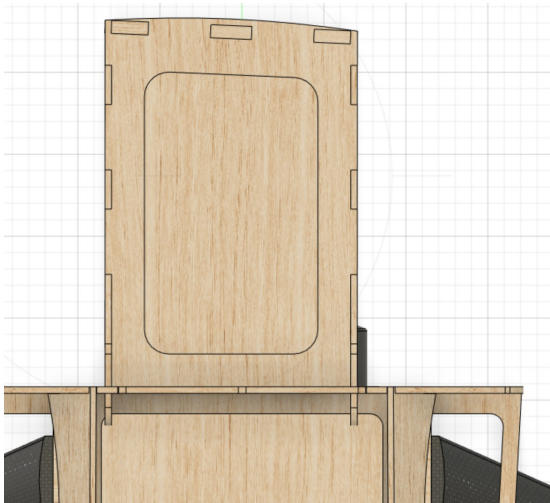

At the point your fuselage should now look like this :)



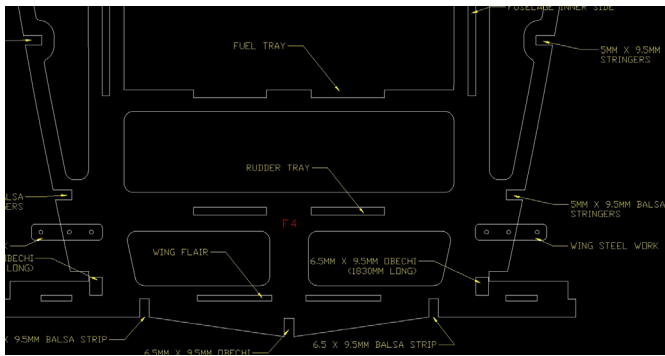

on F4 and F2 you now need to add the steel work for the wings, these are in the Ali Pack supplied with the Kit. ON F4 AND F2 the ali fits in the same place. as shown on drawing,

The Rear UC Steelwork location is shown on the plans

Once these are in place, we are up to sheeting the model :)

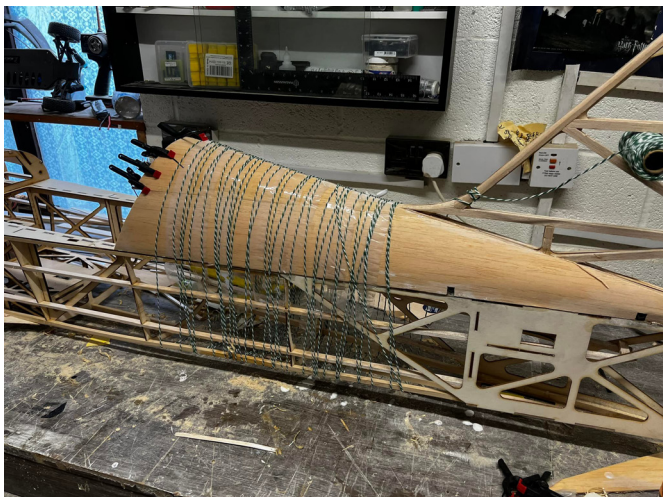

The Rear of the fuselage is sheeted with 2.4mm balsa like the image shows. We prefer to Wet the balsa and use white glue. To keep the shape, we use string to pulled tight to hold in place while it dries.



Ensure you cut the balsa around the rear Elevator Carbon Rods.



There are also a few other areas at the bottom of the model that will need sheeting to make things neat for covering and Rudder Control Wire Exits.



Underside sheeting



Continue to sheet the model in 2.4mm balsa as the photos show.. DO NOT SHEET THE FORWARD TURTLE DECK JUST YET,

Please note, you will need to make a fillet here that blends in to the UC plate.

This is quite difficult to do as it has to profile the wing shape as well.

please take your time while doing it.

You do not need to do this fillet, you can simply add a block and shape to wing flair shape, This is A cosmetic Shape and only if you want scale is it to be done..

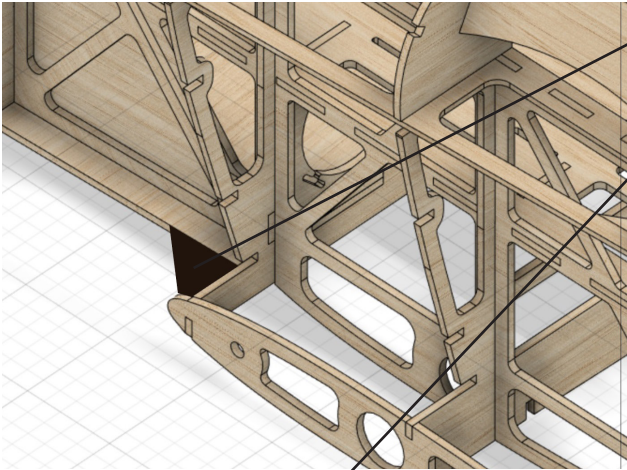



The Cockpit frame can now be assembled on the model, We recommend using greese proof paper, so it does now stick to the model.

Balsa stringers are to be added in the designated places on formers, proir to sheeting,

All of the cockpit frame can be assembled with superglue

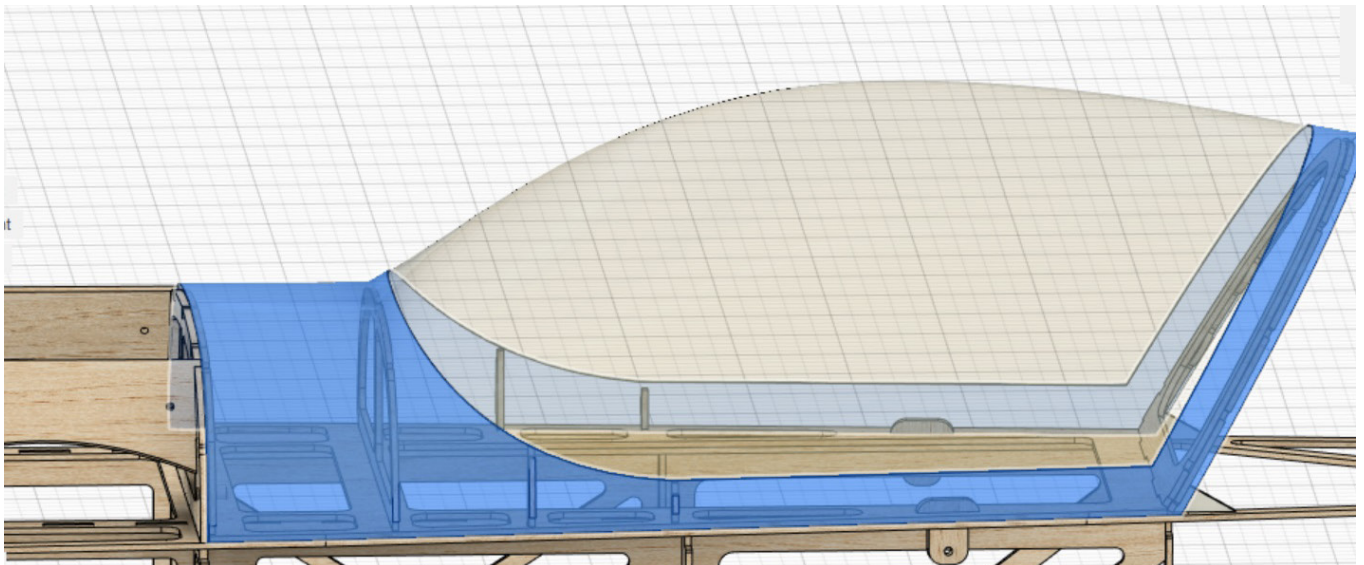

The Cockpit frame is sheeted as shown in the image. Use 2.4mm Balsa

Once sheeted, Give yourself a pat on the back! your fuselage is nearly complete. Next we move on to wings which are a total plan build. Dont worry, Most of the hard work is now done.

As a Tip. We recommend building the top wings as one, this helps with getting the wings identical. If you cannot do this, then please make Jigs on the plans to ensure they are build accurate

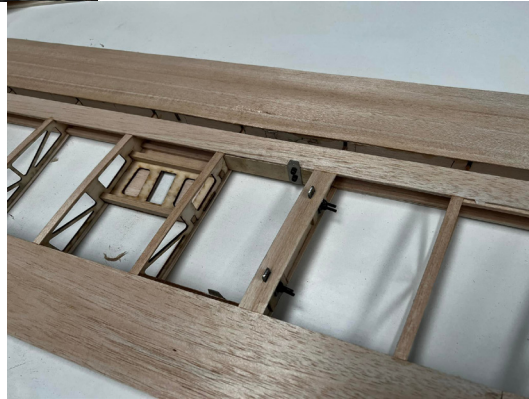
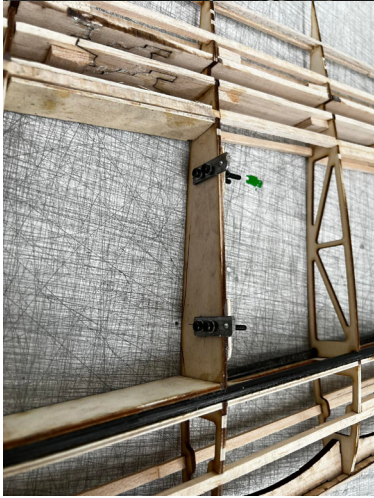

Time To align the top wings

The Interplain Struts are fully sheeted both sides with 3.2mm Balsa.

In the woods, you will also find the hard point woods that are to be used to hold the 3mm captive nuts,



Time To align the top wings

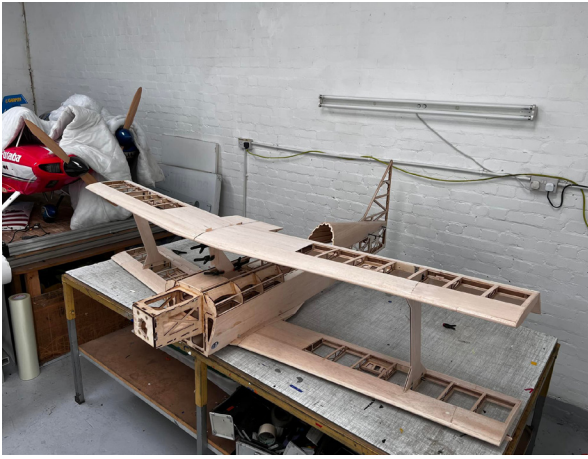

TO MAKE THINGS EASY, YOU CAN DRILL AND BOLT THE INTERPLANE TO THE BOTTOM WING. PLEASE DO NOT GLUE AT THIS POINT.

IT IS ONLY TO HOLD IN PLACE.

MAKE SURE TO ADD PACKING UNDER BOTTOM WINGS TO KEEP LEVEL. AS THERE ARE NO WING WIRES, THE WINGS COULD SAG UNDER WEIGHT

WITH THE MODEL LEVEL, REST TOP WINGS WITH THE CENTRE JIG IN PLACE WHICH FITS ON THE TOP 4 RIBS OF THE MODEL ENSURE THE WINGS PROFILE AS BEST AS POSSIBLE THE TOP OF THE INTERPLAIN STRUT.

DROP A PLUM LINE FROM TOP WING TIP TO BOTTOM WING TIPS

MEASURE DISTANCE BETWEEN PLUM LINE AND BOTTOM WING LE, THIS DISTANCE NEEDS TO BE THE SAME ON BOTH WINGS.. MAKE SURE WINGS ARE VERTICAL AT TIPS AND WING INCIDENCE IS 0 DEGREES

ONCE ALL MEASUREMENTS ARE EQUAL, WING INCIDENCE IS 0 AND INTERPLANE STRUTS ARE IN THE CORRECT PLACE, YOU CAN DRILL INTERPLANES FOR THE 4MM BOLTS

MAKE SURE TO GLUE CAPTIVE NUTS BOLTED WHILST FITTED TO WINGS (INCLUDING BOTTOM WINGS NOW) AS THE INTERPLANES SHOULD HAVE AN ANGLE. SEE DRAWING.

AFTER GLUE HAS FULLY CURED. YOU CAN NOW TAKE OFF THE TOP WINGS AND THE JOG AND ADD THE BODY CENTRE STRUT. BOLT THE MODEL BACK TOGETHER AND ALIGN THE CENTER STRUT STEEL WORK TO MODEL.

PLEASE MAKE SURE THE CENTER OF THE STEEL WORK AND BODY IS PERFECTLY ALIGNED ON ITS CENTRE LINE AND TOP WING INCIDENCE IS 0 DEGREES.

CHECK ALL OVERHANGS AND WING DISTANCES, ONCE HAPPY. YOU CAN DRILL AND BOLT UP THE CENTER STEEL WORK ONTO THE ANGLED FORMERS USING 3MM BOLTS AND CAPTIVES. ALIGNING THIS WAY IS THE EASIEST WE HAVE FOUND. DO NOT TRY TO POSITION CENTRE STRUT FIRST THEN OUTER STRUTS THE WINGS WILL NOT ALIGN. WHAT YOU ARE TRYING TO DO IS FIT A TOP WING IN ALIGNMENT TO BOTTOM WINGS WHICH ARE IN A KNOWN POSITION. THINK ABOUT IT FOR A WHILE.



Once complete, Add the final few 4mm x 4mm Balsa Stringers with superglue, and sheet the top section of the model.

We tend to make a ply hatch to go here so you can access the tank from above as well as below

Congratulations, you are now up to finishing your model, covering, adding your own personal preference of electronics..

If you need any advice, please get in touch!

